

Warranty, Service & Repair

To register your product with the manufacturer, go to the Flowline website for on-line registration. The website address is as follows:

www.flowline.com

On-line Warranty Registration can be found under Contact Us in the Navigation Bar along the side of the home page.

If for some reason your product must be returned for factory service, contact Flowline Inc. at (562)598-3015 to receive a Material Return Authorization number (MRA), providing the following information:

1. Part Number, Serial Number
2. Name and telephone number of someone who can answer technical questions related to the product and its application.
3. Return Shipping Address
4. Brief Description of the Symptom
5. Brief Description of the Application

Once you have received a Material Return Authorization number, ship the product prepaid in its original packing to:

Flowline Factory Service
MRA _____
10500 Humbolt Street
Los Alamitos, CA 90720

To avoid delays in processing your repair, write the MRA on the shipping label. Please include the information about the malfunction with your product. This information enables our service technicians to process your repair order as quickly as possible.

FLOWLINE®

MicroPoint™ Multi-Channel Indicator with Alarms LI42 Series (2-Channel) Owner's Manual



Version 2.1A

© 2004 FLOWLINE Inc.

All rights reserved.

Manual # LI900004 - 0410-LI42M2_1

WARRANTY

Flowline warrants to the original purchaser of its products that such products will be free from defects in material and workmanship under normal use and service for a period which is equal to the shorter of one year from the date of purchase of such products or two years from the date of manufacture of such products.

This warranty covers only those components of the products which are non-moving and not subject to normal wear. Moreover, products which are modified or altered, and electrical cables which are cut to length during installation are not covered by this warranty.

FLOWLINE's obligation under this warranty is solely and exclusively limited to the repair or replacement, at FLOWLINE's option, of the products (or components thereof) which FLOWLINE's examination proves to its satisfaction to be defective. FLOWLINE SHALL HAVE NO OBLIGATION FOR CONSEQUENTIAL DAMAGES TO PERSONAL OR REAL PROPERTY, OR FOR INJURY TO ANY PERSON.

This warranty does not apply to products which have been subject to electrical or chemical damage due to improper use, accident, negligence, abuse or misuse. Abuse shall be assumed when indicated by electrical damage to relays, reed switches or other components. The warranty does not apply to products which are damaged during shipment back to FLOWLINE's factory or designated service center or are returned without the original casing on the products. Moreover, this warranty becomes immediately null and void if anyone other than service personnel authorized by Flowline attempts to repair the defective products.

Products which are thought to be defective must be shipped prepaid and insured to FLOWLINE's factory or a designated service center (the identity and address of which will be provided upon request) within 30 days of the discovery of the defect. Such defective products must be accompanied by proof of the date of purchase.

Flowline further reserves the right to unilaterally waive this warranty and to dispose of any product returned to Flowline where:

- a. There is evidence of a potentially hazardous material present with product.
- b. The product has remained unclaimed at Flowline for longer than 30 days after dutifully requesting disposition of the product.

THERE ARE NO WARRANTIES WHICH EXTEND BEYOND THE DESCRIPTION ON THE FACE OF THIS WARRANTY. This warranty and the obligations and liabilities of Flowline under it are exclusive and instead of, and the original purchaser hereby waives, all other remedies, warranties, guarantees or liabilities, express or implied. EXCLUDED FROM THIS WARRANTY IS THE IMPLIED WARRANTY OF FITNESS OF THE PRODUCTS FOR A PARTICULAR PURPOSE OR USE AND THE IMPLIED WARRANTY OF MERCHANTABILITY OF THE PRODUCTS.

This warranty may not be extended, altered or varied except by a written instrument signed by a duly-authorized officer of Flowline, Inc.

SPECIFICATIONS

Step One

Display type:	LCD, 5-digit
Display units:	Factory cal: % of span PC cal: engineering*
Decimal point:	Floating
Display output:	Transmitter: 0-99999 Switch: Good / alarm*
Display height:	0.4" (1 cm)
Display backlight:	LED bar (adjustable)
Linearization:*	2-16-point function
User interface:	Single push button
Input channels:	(2) 4-20 mA
Loop insertion:	In-series, 10 Ohms
Supply voltage:	12-24 VDC
PC-cal. interface:*	USB® adapter w/cable
PC-cal. software:*	MicroCal (Windows®)
Memory:	Non-volatile
Alarm type:*	(2) FET switches with opt. audible chirp
Alarm cancel:*	Single push button
Alarm set points:*	1 point: alarm 2 points: out of bounds
Switch rating:*	1A @ 24 VDC
Switch output:*	Normally open
Operating temp.:	F: -4° to 140° C: -20° to 60°
Cable type:	10-conductor, #22 AWG
Cable length:	10' (3m)
Enclosure rating:	NEMA 4X (IP65)
Enclosure material:	PC/ABS FR
Enclosure mount:	Panel or field
Button material:	Silicon rubber
Classification:	General purpose
CE compliance:	EN 61326 (1997) Class A and CISPR 11 (1997) Class A Group 1

* Requires the LI96-1001 MicroCal calibration kit (sold separately) which includes: (1) PC Windows based MicroCal software CD and (1) USB to RS485 adapter with 1m cable.

**LI42-1001
Indicator Front View**

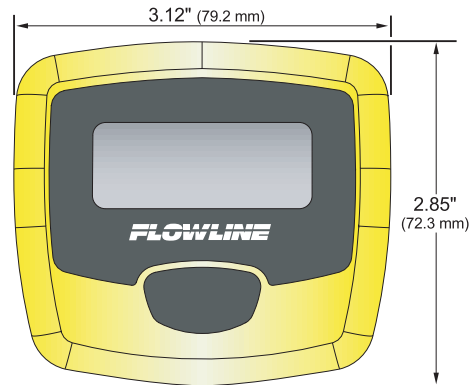

**LI42-1001
Indicator Side View**

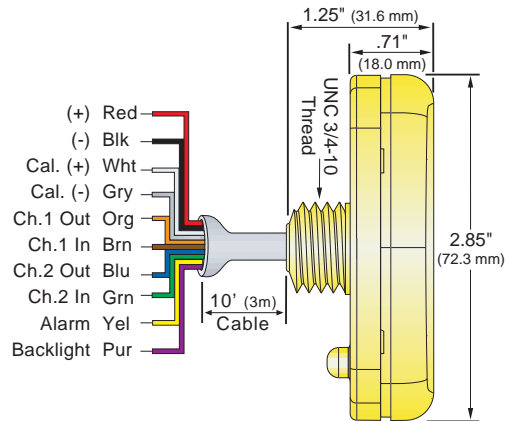

**LI42-1001
Wall Bracket Holes**

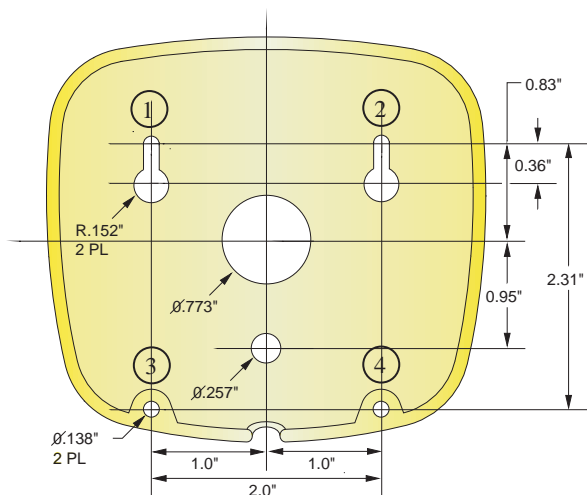

Use the above hole dimensions for purposes of drilling the (4) wall bracket mounting holes.

**LI42-1001
Wall Bracket Front / Side Views**

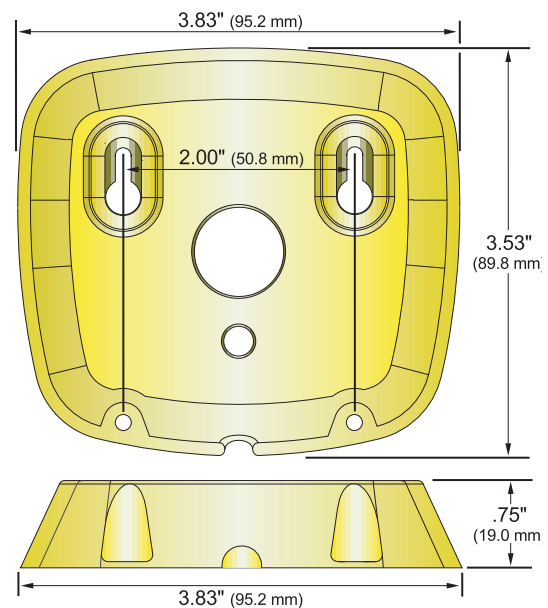

SAFETY

Step Two

⚠ About this Manual: PLEASE READ THE ENTIRE MANUAL PRIOR TO INSTALLING OR USING THIS PRODUCT. This manual includes information on the LI42-1001 Multi-channel level indicator from FLOWLINE. Please refer to the part number located on the indicator label to verify the exact model configuration which you have purchased.

⚠ User's Responsibility for Safety: FLOWLINE manufactures a broad range of level sensing technologies. While each of these sensors is designed to operate in a wide variety of applications, it is the user's responsibility to select a sensor model that is appropriate for the application, install it properly, perform tests of the installed system, and maintain all components. The failure to do so could result in property damage or serious injury.

⚠ Proper Installation and Handling: Only properly trained staff should install and/or repair this product. Always check for leaks prior to system start-up.

⚠ Wiring and Electrical: A supply voltage of 12-24 VDC is used to power the LI42-1001 indicator. The sensor circuit should never exceed a maximum of 24 volts DC. Electrical wiring of the sensor should be performed in accordance with all applicable national, state, and local codes.

⚠ Material Compatibility: The LI42-1001 indicator is made of a flame retardant Polycarbonate (PC/ABS FR). Make sure that the model which you have selected is chemically compatible with the application media.

⚠ Enclosure: While the indicator housing is liquid-resistant the LI42-1001 is not designed to be immersed. Make sure that the indicator is mounted in an appropriate location such that under normal operating conditions, it cannot come into contact with the application media.

⚠ Make a Fail-Safe System: Design a fail-safe system that accommodates the possibility of indicator and/or power failure. FLOWLINE recommends the use of redundant backup systems and alarms in addition to the primary system.

⚠ Flammable, Explosive or Hazardous Applications: The LI42-1001 should not be used within classified hazardous environments.

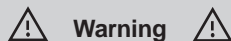

Warning

Electrical wiring should be performed in accordance with applicable national, state, and local codes. Only properly trained personnel should install or repair this product.

OVERVIEW

Step Three

A. Application: Factory calibrated, the general purpose indicator reads 0-100% of span with TWO level transmitter input channels. A single push button allows users to scroll through active channels. The compact NEMA 4X enclosure supports panel and wall mount installations.

B. Part Number: The part and serial numbers are located on the back of the indicator. To access the label, remove the locking nut and separate the mounting bracket from the indicator. Check the part number on the product label and confirm which of the below model configurations you have purchased:

Part Number	Inputs	Output(s)	PLC Loop
LI42-1001	2	(2) FET	Yes
LI44-1001	4	(1) FET	No

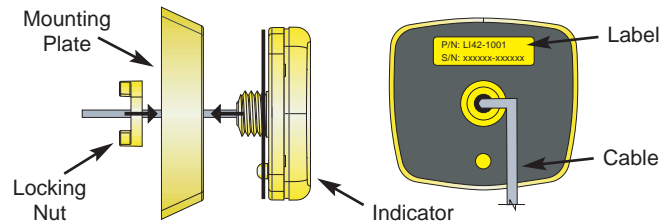

C. MicroCal Calibration Kit: With the optional LI96-1001 MicroCal PC calibration kit (purchased separately), users can greatly expand the indicators functionality to customize engineering units, configure FET alarm set points from level transmitter, level switch or leak detection switch inputs, and/or linearize the volumetric measurement of odd shaped tanks. Each kit includes (1) PC Windows® based MicroCal software CD and (1) USB to RS485 adapter with 1m cable.

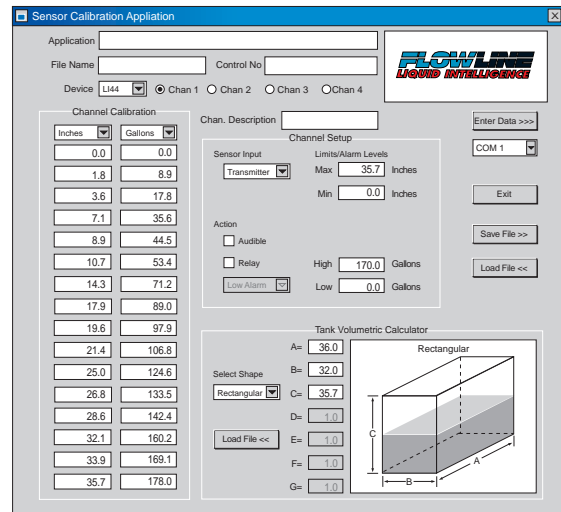

PREPARATION

Step Four

A. Supply Voltage: The maximum indicator power supply voltage should never exceed 24 VDC. Power supplies with a minimum voltage of 12 VDC may be used to power the indicator during calibration and/or operation.

B. Indicator Cable: The PVC jacketed indicator cable is 10' (3m) in length. If the cable must be shortened, carefully strip and remove the outer jacket. Using a 22 gauge wire stripper, remove the last 1/4" of colored insulation from each wire. The following legend identifies the indicator wire functions:

Red: (+) 12-24 VDC supply

Black: (-) 12-24 VDC supply

White: (+) Calibration wire

Gray: (-) Calibration wire

Brown: Chan-1 sensor input

Orange: Chan-1 sensor return

Green: Chan-2 sensor input

Blue: Chan-2 sensor return

Yellow: Chan-1 FET switch

Purple: Chan-2 FET switch

Indicator Wires

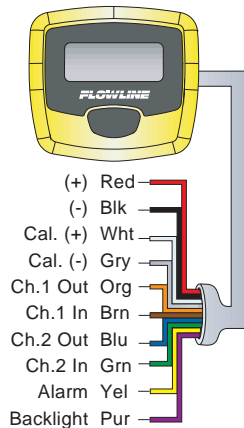

C. Sensor Cable: The maximum cable distance between the indicator and attached Flowline transmitter, level or leak detection switch is 1000 feet (304m). Use a well insulated and shielded twisted pair cable sized from 14-18 gauge.

D. FET Cable: The maximum cable distance between the indicator FET switch and the attached PLC or stepper relay (connected to the pump, valve or alarm) is 250 feet (76m). Use a well insulated and shielded cable sized from 14-18 gauge.

E. FET Fail-Safe Design: Disabled unless otherwise programmed via MicroCal, the indicator has (2) SINKING FET (N-Channel) switch channels rated 1A @ 24 VDC. Normally open (NO) or normally closed (NC) operation is user calibrated based on the desired system control and fail-safe logic. **Always design a fail-safe system that accommodates for the possibility of FET switch and/or power failure. An appropriately rated DC-COIL STEPPER RELAY should always be placed in between the FET and load (pumps, valves and alarms) to avoid damaging the FET switch.**

F. Audible Alarm: Disabled unless otherwise programmed via MicroCal, the audible chirp alarm will activate during an alarm event. To cancel the alarm, press the push button once. This will NOT effect the FET switch that will remain in the alarm state until the measured value returns to the acceptable range.

G. Backlight: For viewing at night or in dimly lit applications, the indicator has an adjustable backlight that is turned OFF when shipped from the factory. To turn the backlight ON, press and hold down the push button. The backlight intensity will cycle from OFF to HIGH and back to OFF. Release the button at the desired backlight intensity.

CALIBRATION

Step Five

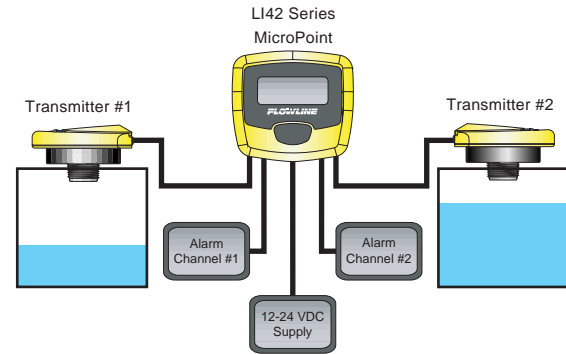

A. Factory Calibration: Out of the box, the indicator is factory calibrated to interface with (2) SOURCING two-wire loop powered level transmitter inputs and display percentage of measured span on each channel. The following describes the indicator functions as delivered under factory calibration:

Function	Factory Calibration
Chan-1 sensor input:	4 mA = 0.0% 20 mA = 100.0%
Chan-2 sensor input:	4 mA = 0.0% 20 mA = 100.0%
Display decimal point:	1-place (100.0%)
Chan-1 FET switch:	Not enabled
Chan-2 FET switch:	Not enabled
Backlight:	OFF

B. Percentage of Span: To optimize the percentage of span indication, it is recommended that the level transmitter(s) span be properly calibrated with 4 mA placed near tank EMPTY and 20 mA placed near tank FULL. The indicator can then read the entire 0-100% span. Please refer to the appropriate level transmitter owners manual(s) for specific calibration instructions. **Factory calibration users should now go to the Installation Section of this manual.**

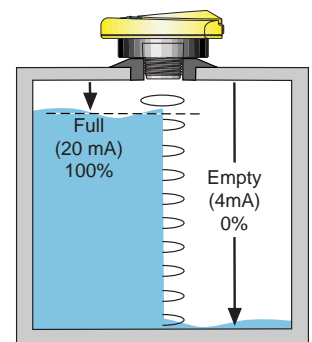

C. MicroCal Calibration: To customize engineering units, configure FET alarm set points from level transmitter, level switch or leak detection switch inputs, and/or linearize the volumetric measurement of odd shaped tanks, use the MicroCal calibration kit. **MicroCal calibration users should now go to the MicroCal Calibration Kit LI96 Series Owners Manual for programming instructions. Once calibrated, return to this manual and continue starting with the Installation Section.**

INSTALLATION

Step Six

A. Introduction: The NEMA 4X indicator is designed to support both panel and wall mount installations. Panel mount installations are generally used when the indicator is remote from the tank(s) and placed in a consolidated instrument panel. Conversely, wall mount installations are generally used when the indicator is installed at the tank(s) for local viewing.

B. Panel Mount: Follow the below steps to install the indicator in a panel mount configuration:

1. Drill (1) large 0.75" (19mm) diameter hole in the panel for the cable and nipple.
2. Drill (1) small 0.25" (6mm) diameter hole 0.95" (24mm) below the large hole that will prevent the installed indicator from rotating off center.
3. Run the indicator cable through the flat gasket, large top hole and locking nut (on the rear side of the panel).
4. Properly align the indicator with the flat gasket and holes on the panel. Then press in place.
5. Tighten the locking nut down over the nipple and route the cable for termination.

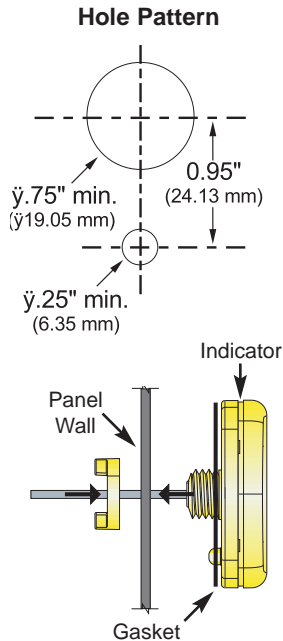

C. Wall Mount: Follow the below steps to install the indicator in a wall mount configuration:

1. Unscrew the locking nut from the nipple and separate the wall bracket from the indicator.
2. Drill (4) screw mounting holes (screws not provided) consistent with the bracket hole pattern and/or dimensions shown in the Specification Section.
3. Install the (2) top screws leaving room for the wall bracket to be placed over the screws.
4. Run the indicator cable through the flat gasket and large top hole on the wall bracket.
5. Press the indicator assembly together and tighten the locking nut down over the nipple.
6. With the cable routed through the cut-out at the bottom of the wall bracket, place the indicator over the (2) mounting screws and slide it down.
7. Install the (2) bottom screws on the bracket and route the cable for junction box termination.

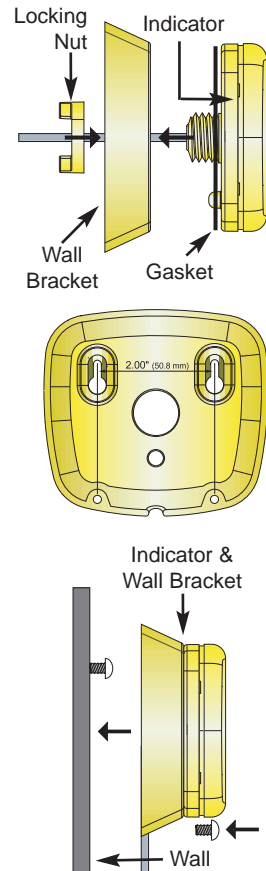

WIRING

Step Seven

A. Wiring the LI42-1001 to (1) Level Transmitter and (1) Alarm (Note: Alarm Functions Require MicroCal Calibration)

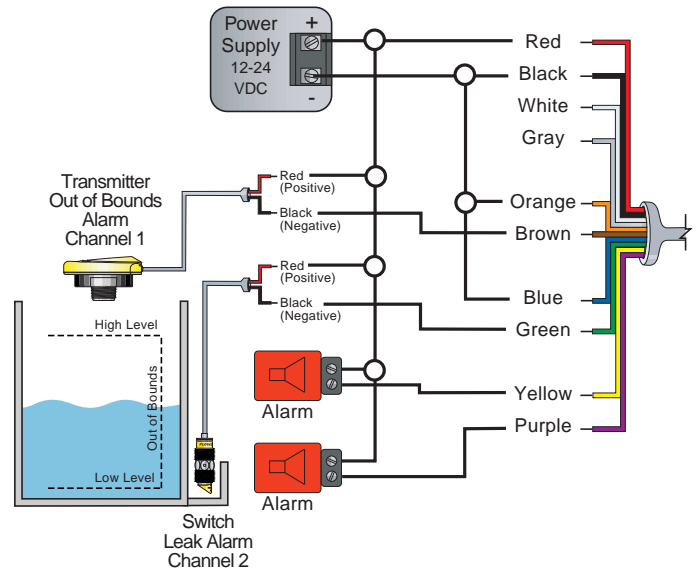

Warning

Always read the associated transmitter and/or switch instruction manual(s) and check the power supply min-max rating(s) prior to wiring.

B. Wiring the LI42-1001 to (1) Level Transmitter, (1) Level Switch, (1) PLC and (1) Alarm (Note: Switch and Alarm Functions Require MicroCal)

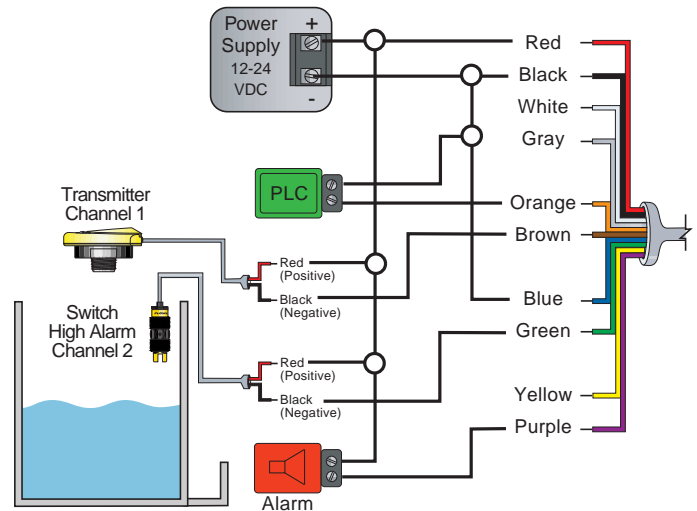

Warning

Always read the associated transmitter and/or switch instruction manual(s) and check the power supply min-max rating(s) prior to wiring.

WIRING

Step Seven

C. Wiring the LI42-1001 to (1) Level Transmitter, (1) Level Switch (2) Alarms and (1) PLC (Note: Switch and Alarm Functions Require MicroCal Calibration)

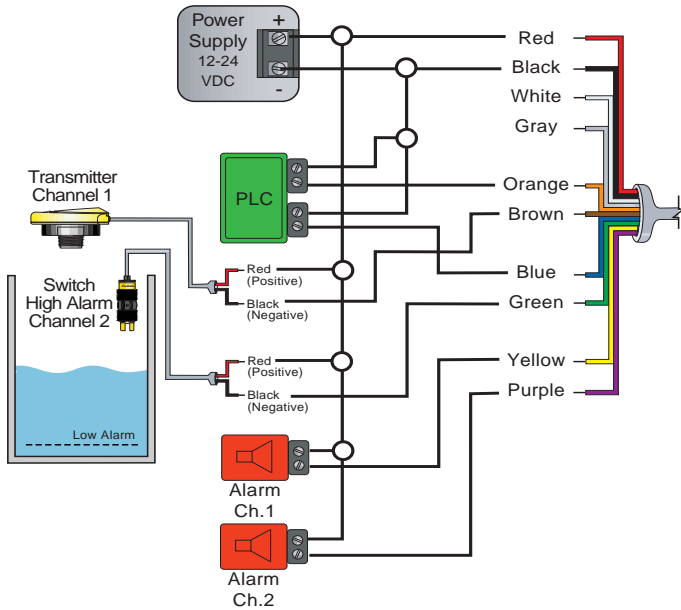

Warning

Always read the associated transmitter and/or switch instruction manual(s) and check the power supply min-max rating(s) prior to wiring.

D. Wiring the LI42-1001 to (2) Level Transmitters, (1) PLC and (2) Alarms (Note: Alarm Functions Require MicroCal Calibration)

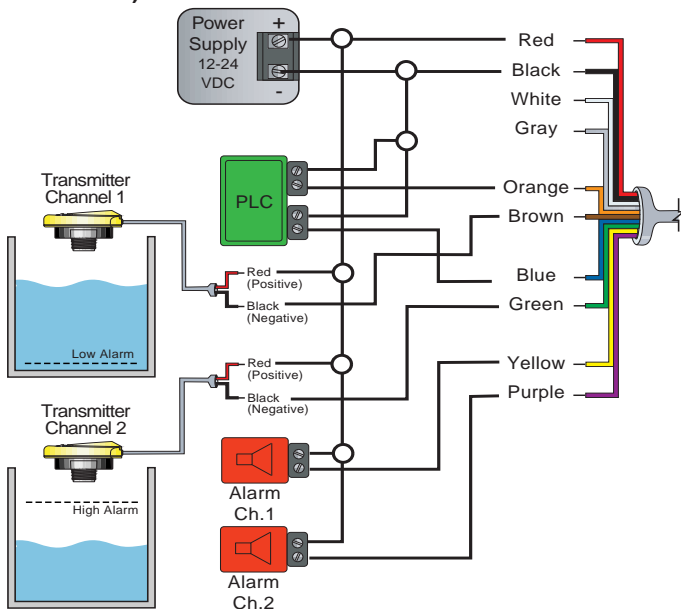

Warning

Always read the associated transmitter and/or switch instruction manual(s) and check the power supply min-max rating(s) prior to wiring.

TROUBLESHOOTING

Step Eight

A. Display Descriptors: The following are the display's operational descriptors, meaning and corrective action:

CH=_ Momentarily indicates the displayed channel number (CH=1) after the push button is pressed and before the measured value is displayed (Factory and MicroCal functions).

CH=L When the transmitter measured value falls below the programmed LOW level set point, the display automatically redirects to that ALARM state channel (CH1=L). The display then alternates between the channel descriptors (CH1=L) and the measured value as programmed via MicroCal. The ALARM will automatically clear when the measured value rises 10% above the set point (MicroCal function only).

CH=H When the transmitter measured value goes above the programmed HIGH level set point, the display automatically redirects to that ALARM state channel (CH2=H). The display then alternates between the channel descriptors (CH2=H) and the measured value as programmed via MicroCal. The ALARM will automatically clear when the measured value falls 10% below the set point (MicroCal function only).

Good The level or leak detection switch is in a NORMAL state (wet or dry) as programmed via MicroCal. The ALARM will automatically clear when the switch input changes state (MicroCal function only).

CH_HI The HIGH level switch (CH1HI) is in an ALARM state (wet) as programmed via MicroCal. The ALARM will automatically clear when the switch input changes state (MicroCal function only).

CH_LO The LOW level switch (CH2LO) is in an ALARM state (dry) as programmed via MicroCal. The ALARM will automatically clear when the switch input changes state (MicroCal function only).

CH_LE The LEAK detection switch (CH1LE) is in an ALARM state (wet) as programmed via MicroCal. The ALARM will automatically clear when the switch input changes state (MicroCal function only).

ALLUC If the current consumption on BOTH 4-20 mA sensor input channels falls below 1 mA, then the display will read ALLUC. This indicates that there are either NO sensors attached and/or loop power to the sensors.

CH_OL If the current consumption of a 4-20 mA sensor input rises above 25 mA, then that channel (CH2OL) will be automatically disabled. Correct the overload condition and cycle power to the indicator. Severe or repeated overloading may cause permanent damage.

B. Additional Information: Go to www.digitalinfinity.com and click on the nav-bar "Application Info" button for FAQ's, tech-tips, case studies, white papers, glossary and success stories.